

# Thermal Overload Connection Diagrams

Thermal protectors are supplied loose as standard in all single phase motors. If you choose to wire the thermal protector into your power circuit, you need to follow the instructions below. Depending on the blower model, the thermal protector can be wired to operate in either an automatic or pilot duty mode only. For use in a pilot duty mode, a starter with an auxiliary relay is required. Two black leads (except for the RB3-101-1 which has three leads) in the conduit box belong to the thermal protector and are referred to below.

## AUTO RESTART DUAL VOLTAGE MOTORS WIRED WITH THERMAL OVERLOAD IN CIRCUIT

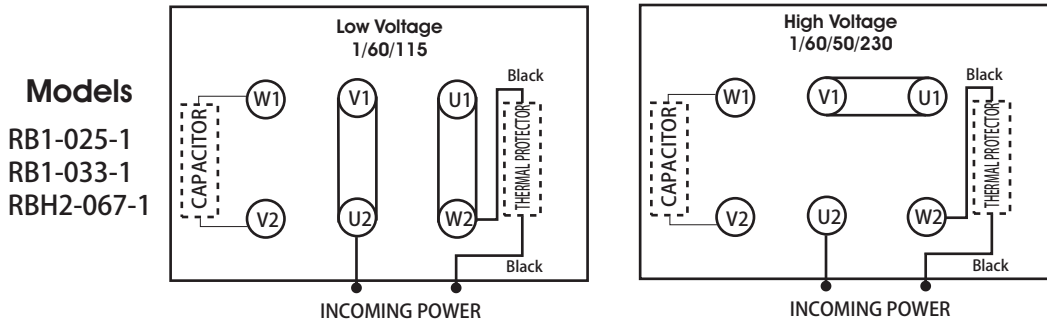

1. The capacitor connection to W1 and V2 is already connected at the factory.
2. Remove the metal spade connectors on the two black wires.
3. Connect these two black wires as follows:
  - a. Connect one of the black leads to terminal W2.
  - b. Connect the other black leads to the incoming power.
4. Brass metal jumpers (connectors) should be attached as shown above, between V1 and U2; U1 and W2 and for high voltage, between V1 and U1.

## PILOT DUTY DUAL VOLTAGE MOTORS - REQUIRES A MOTOR STARTER WITH AN AUXILLARY RELAY

**\*\* Note: The thermal protector in these models can be wired for Auto or Pilot Duty.**

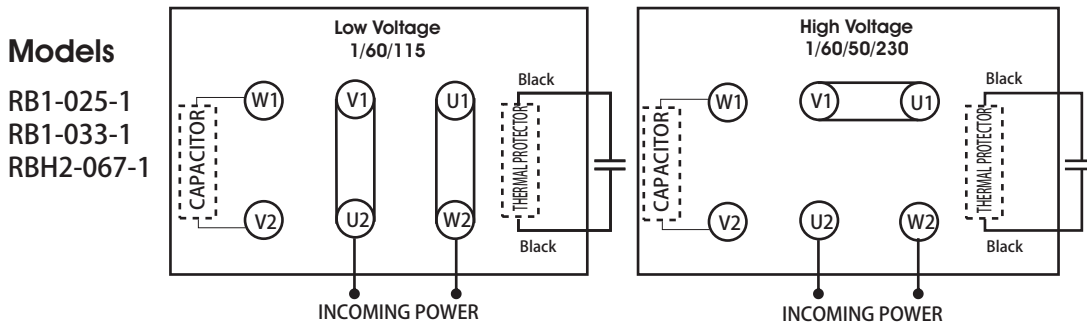

## SINGLE VOLTAGE 1/60/50/230 - PILOT DUTY ONLY - REQUIRES A MOTOR STARTER WITH AN AUXILIARY RELAY

### Models

RBH3-105-2  
RBH3-2-2  
RBH33-2-2  
RBH4-105-2  
RBH4-2-2  
RBH4-205-2  
RBH43-305-2  
RBH6-305-2  
RBH6-5-2

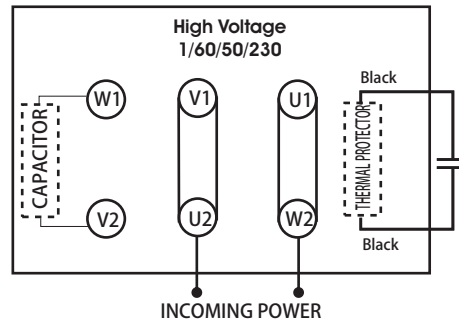

Note: As noted below, the RB3-101-1 has three leads to connect the thermal protector.

